

**CMOS 12 X 8 CROSSPOINT WITH CONTROL MEMORY**

- LOW ON RESISTANCE  
(typ. 60 Ω at  $V_{DD} = 10\text{ V}$ )
- INTERNAL CONTROL LATCHES
- ANALOG SIGNAL SWING CAPABILITY EQUAL TO POWER SUPPLY VOLTAGE APPLIED
- LESS THAN 1 % TOTAL DISTORT. AT 0 dBm
- LESS THAN - 95 dB CROSS-TALK  
AT 1 KHz 1  $V_{PP}$
- VERY LOW POWER CONSUMPTION
- PIN-TO-PIN COMPATIBLE WITH M093



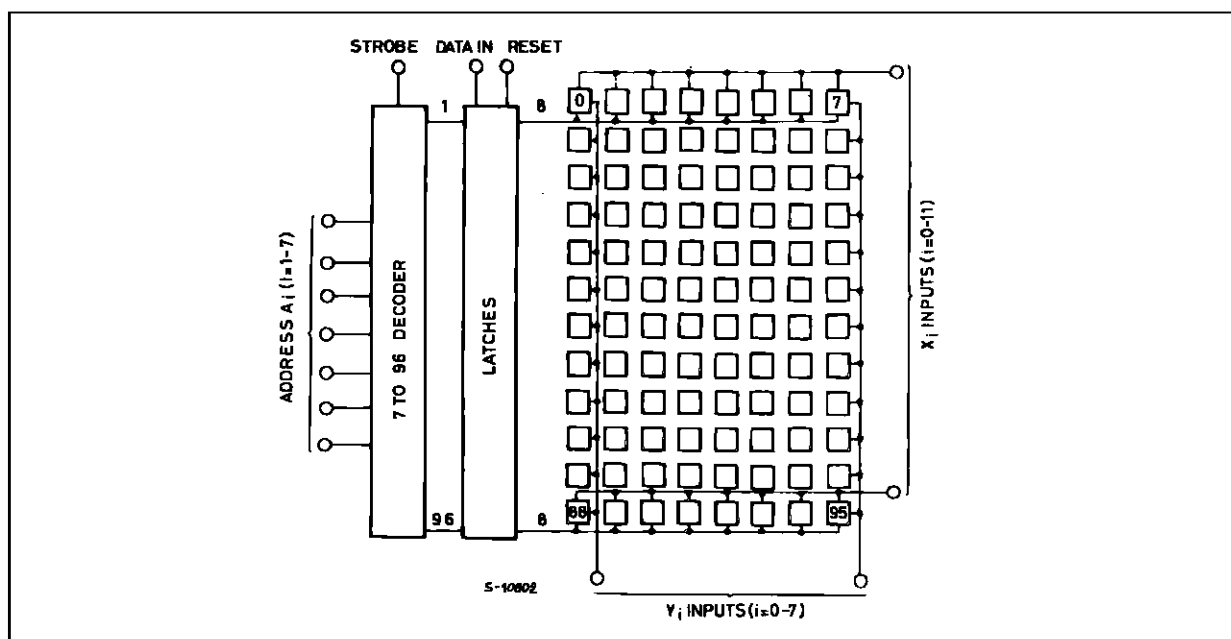
**DESCRIPTION**

The M3493 contains a 12 x 8 array of crosspoint together with a 7 to 96 line decoder and latch circuits. Anyone of the 96 switches can be addressed by selecting the appropriate 7 input bits. The selected switch can be turned on or off by applying a logical one or zero to the data in and the strobe input at logi-

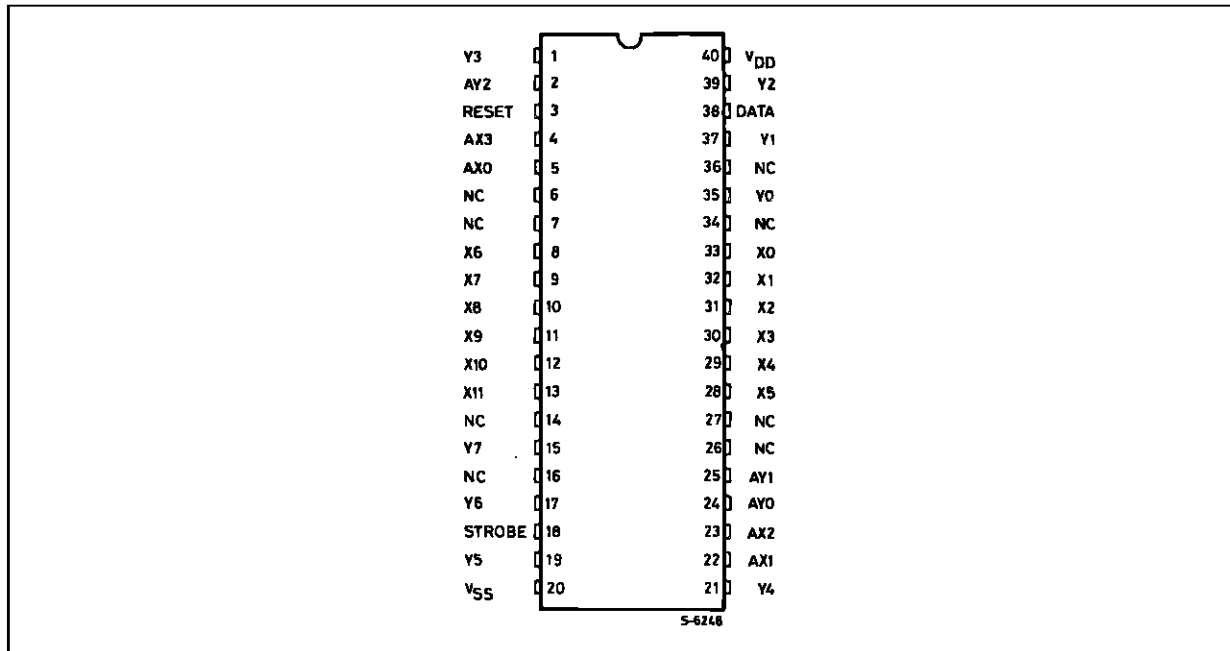
cal one. A reset signal can be used to turn off all the switches together when is switched at logical one.

M3493 is available in 40 lead dual in-line plastic package.

**BLOCK DIAGRAM**



**PIN CONNECTION** (top view)



**INPUT/OUTPUT DESCRIPTION**

| I/O | Symbol | Pin | Description |
|-----|--------|-----|-------------|
|-----|--------|-----|-------------|

**POWER**

|   |                 |    |                       |
|---|-----------------|----|-----------------------|
| I | V <sub>DD</sub> | 40 | Positive Power Supply |
| I | V <sub>SS</sub> | 20 | Negative Power Supply |

**ADDRESS**

|   |         |              |  |
|---|---------|--------------|--|
| I | AX0-AX3 | 4, 5, 22, 23 | X Address Lines. These 4 pins are used to select one of the 12 rows of switches. Refer to the truth table for legal address.   |
| I | AY0-AY2 | 2, 24, 25    | Y Address Lines. These 3 pins are used to select one of the 8 columns of switches. Refer to the truth table for legal address. |

**CONTROL**

|   |        |    |   |
|---|--------|----|---|
| I | DATA   | 38 | This input determines if the selected switch will be turned on (closed) or off (opened). If the pin is held high, the selected switch will be closed. If the pin is held low, the switch will be opened.  |
| I | STROBE | 18 | This pin enables whatever action is selected by the ADDRESS and DATA pins. When the STROBE pin is held low, no switch openings or closings take place. When the STROBE pin is held high, the switch addressed by the select lines will be opened or closed (depending upon the state of the DATA pin) |
| I | RESET  | 3  | Master Reset. This pin turns off (opens) all 96 switches. The states of the above control lines are irrelevant. This pin is active high.  |

**DATA**

|     |        |                           |  |
|-----|--------|---------------------------|--|
| I/O | X0-X11 | 8-13, 28-33               | Analog Input/Outputs. These pins are connected to the Y0-Y7 pins in according to the truth table.  |
| I/O | Y0-Y7  | 1,15,17,19,21<br>35,37,39 | Analog Input/Outputs. These pins are connected to the X0-X15 pins in according to the truth table. |

## TRUTH TABLE

| Address |     |     |     |     |     |     | Connections   |
|---------|-----|-----|-----|-----|-----|-----|---------------|
| AX0     | AX1 | AX2 | AX3 | AY0 | AY1 | AY2 |               |
| 0       | 0   | 0   | 0   | 0   | 0   | 0   | X0 - Y0       |
| 1       | 0   | 0   | 0   | 0   | 0   | 0   | X1 - Y0       |
| 0       | 1   | 0   | 0   | 0   | 0   | 0   | X2 - Y0       |
| 1       | 1   | 0   | 0   | 0   | 0   | 0   | X3 - Y0       |
| 0       | 0   | 1   | 0   | 0   | 0   | 0   | X4 - Y0       |
| 1       | 0   | 1   | 0   | 0   | 0   | 0   | X5 - Y0       |
| 0*      | 1   | 1   | 0   | 0   | 0   | 0   | No connection |
| 1*      | 1   | 1   | 0   | 0   | 0   | 0   | No connection |
| 0       | 0   | 0   | 1   | 0   | 0   | 0   | X6 - Y0       |
| 1       | 0   | 0   | 1   | 0   | 0   | 0   | X7 - Y0       |
| 0       | 1   | 0   | 1   | 0   | 0   | 0   | X8 - Y0       |
| 1       | 1   | 0   | 1   | 0   | 0   | 0   | X9 - Y0       |
| 0       | 0   | 1   | 1   | 0   | 0   | 0   | X10 - Y0      |
| 1       | 0   | 1   | 1   | 0   | 0   | 0   | X11 - Y0      |
| 0*      | 1   | 1   | 1   | 0   | 0   | 0   | No connection |
| 1*      | 1   | 1   | 1   | 0   | 0   | 0   | No connection |
| 0       | 0   | 0   | 0   | 1   | 0   | 0   | X0 - Y1       |
| ↓       | ↓   | ↓   | ↓   | ↓   | ↓   | ↓   | ↓ <0> ↓       |
| 1       | 0   | 1   | 1   | 1   | 0   | 0   | X11 - Y1      |
| 0       | 0   | 0   | 0   | 0   | 1   | 0   | X0 - Y2       |
| ↓       | ↓   | ↓   | ↓   | ↓   | ↓   | ↓   | ↓             |
| 1       | 0   | 1   | 1   | 0   | 1   | 0   | X11 - Y2      |
| 0       | 0   | 0   | 0   | 1   | 1   | 0   | X0 - Y3       |
| ↓       | ↓   | ↓   | ↓   | ↓   | ↓   | ↓   | ↓             |
| 1       | 0   | 1   | 1   | 1   | 1   | 0   | X11 - Y3      |
| 0       | 0   | 0   | 0   | 0   | 0   | 1   | X0 - Y4       |
| ↓       | ↓   | ↓   | ↓   | ↓   | ↓   | ↓   | ↓             |
| 1       | 0   | 1   | 1   | 0   | 0   | 1   | X11 - Y4      |
| 0       | 0   | 0   | 0   | 1   | 0   | 1   | X0 - Y5       |
| ↓       | ↓   | ↓   | ↓   | ↓   | ↓   | ↓   | ↓             |
| 1       | 0   | 1   | 1   | 1   | 0   | 1   | X11 - Y5      |
| 0       | 0   | 0   | 0   | 0   | 1   | 1   | X0 - Y6       |
| ↓       | ↓   | ↓   | ↓   | ↓   | ↓   | ↓   | ↓             |
| 1       | 0   | 1   | 1   | 0   | 1   | 1   | X11 - Y6      |
| 0       | 0   | 0   | 0   | 1   | 1   | 1   | X0 - Y7       |
| ↓       | ↓   | ↓   | ↓   | ↓   | ↓   | ↓   | ↓             |
| 1       | 0   | 1   | 1   | 1   | 1   | 1   | X11 - Y7      |

## ABSOLUTE MAXIMUM RATINGS

| Symbol            | Parameter                   | Value                        | Unit |
|-------------------|-----------------------------|------------------------------|------|
| V <sub>DD</sub>   | DC supply Voltage           | - 0.5, 14                    | V    |
| V <sub>IN</sub>   | Input Voltage Range         | - 0.5, V <sub>DD</sub> + 0.5 | V    |
| P <sub>tot</sub>  | Power Dissipation           | 1                            | W    |
| T <sub>oper</sub> | Operating Temperature Range | 0, + 70                      | °C   |
| T <sub>stg</sub>  | Storage Temperature Range   | - 50, + 125                  | °C   |

Stresses above those listed under "Absolute Maximum Ratings" may cause permanent damage to the device. This is a stress rating only and functional operation of the device at these or any other conditions in excess of those indicated in the operational sections of this specification is not implied. Exposure to absolute maximum rating conditions for extended periods may affect device reliability.

## RECOMMENDED OPERATING CONDITIONS

| Symbol            | Parameter             | Value              | Unit |
|-------------------|-----------------------|--------------------|------|
| V <sub>DD</sub>   | Supply Voltage        | 10                 | V    |
| T <sub>oper</sub> | Operating Temperature | 0, + 70            | °C   |
| V <sub>IN</sub>   | (Logic Signal)        | 0, V <sub>DD</sub> | V    |

**STATIC ELECTRICAL CHARACTERISTICS** ( $T_{amb} = 0$  to  $70^{\circ}\text{C}$ ,  $V_{DD} = 10\text{V}$ , unless otherwise specified)

| Symbol | Parameter      | Test Conditions  | Min. | Typ. | Max. | Unit |
|--------|----------------|------------------|------|------|------|------|
| $I_S$  | Supply Current | Reset = $V_{DD}$ |      |      | 1    | mA   |

**CROSSPOINT**

|  |                         |   |  |    |         |               |
|--|-------------------------|---|--|----|---------|---------------|
|  | On Resistance           | $V_{IDC} = 4.75\text{V}$ , $V_{ODC} = 4.5\text{V}$ , See Figure 1 |  | 60 | 100     | $\Omega$      |
|  | On Resistance Variation |   |  | 10 | 20      | $\Omega$      |
|  | Off-leakage *           | All switches off $V_{OS} = V_{IS} = 0$ to $V_{DD}$                |  |    | $\pm 3$ | $\mu\text{A}$ |

**CONTROLS**

|          |                 |                          |     |  |         |               |
|----------|-----------------|--------------------------|-----|--|---------|---------------|
| $V_{IL}$ |                 |                          |     |  | 0.8     | V             |
| $V_{IH}$ |                 |                          | 2.4 |  |         | V             |
|          | Input Leakage * | $V_{IN} = 0$ to $V_{DD}$ |     |  | $\pm 3$ | $\mu\text{A}$ |

\* The device is guaranteed with such limits up to  $70^{\circ}\text{C}$ . At  $25^{\circ}\text{C}$  these limits become  $\pm 100\text{nA}$ .

**DYNAMIC ELECTRICAL CHARACTERISTICS**

( $T_{amb} = 25^{\circ}\text{C}$ ,  $C_L = 50\text{pF}$  all input square wave rise and fall times =  $10\text{ns}$ ,  $V_{DD} = 10\text{V}$ )

| Symbol | Parameter | Test Conditions | Min. | Typ. | Max. | Unit | Fig. |
|--------|-----------|-----------------|------|------|------|------|------|
|--------|-----------|-----------------|------|------|------|------|------|

**CROSSPOINT**

|                          |   |  |        |                 |     |            |   |
|--------------------------|---|--|--------|-----------------|-----|------------|---|
| $t_{PHL}$ ,<br>$t_{PLH}$ | Propagation Delay Time (switch on)<br>Signal Input to Output                  | $R_H = 1\text{k}\Omega$ , $V_{IS} = 2V_{PP}$                         |        | 30              | 100 | ns         | 2 |
|                          | Frequency Response (any switch on)<br>$20 \log (V_{OS}/V_{IS}) = -3\text{dB}$ | $R_H = 81\Omega$ , $V_{IS} = 2V_{PP}$ , $C_L = 3\text{pF}$           |        | 50              |     | MHz        |   |
|                          | Sine Wave Distortion  | $f_q = 1\text{kHz}$ , $R_H = 0.6\text{k}\Omega$ , $V_{IS} = 8V_{PP}$ |        |                 | 1   | %          |   |
|                          | Feed Through (any switches off)   | $f_q = 10\text{kHz}$ , $R_H = 1\text{k}\Omega$ , $V_{IS} = 2V_{PP}$  | -80    |                 |     | dB         | 3 |
|                          | Frequency for Signal Crosstalk<br>Attenuation of 40dB<br>Attenuation of 110dB | $R_H = 1\text{k}\Omega$ , $V_{IS} = 2V_{PP}$                         | 1<br>5 |                 |     | MHz<br>kHz | 4 |
| C                        | Capacitance<br>Xn to Ground<br>Vn to Ground<br>Feed Through                   | $f_q = 1\text{MHz}$ , $V_{IS} = 0.1V_{PP}$                           |        | 15<br>15<br>0.4 |     | pF         |   |
| C                        | Capacitance Logic Input to Ground   | $f_q = 1\text{MHz}$ , $V_{IS} = 0.1V_{PP}$                           |        | 5               |     | pF         |   |

**CONTROLS** ( $t_r$ ,  $t_f = 10\text{ns}$ )

|           |  |   |   |     |     |     |     |         |
|-----------|--|---|---|-----|-----|-----|-----|---------|
| $t_{PSN}$ | Propagation Delay Time Strobe to Output (switch turn-on to high level) | $R_L = 1\text{k}\Omega$ , $C_L = 50\text{pF}$ |   | 150 | 200 | ns  | 5   |         |
| $t_{PZH}$ | Data-in to Output (turn-on to high level)                              |   |   | 150 | 200 | ns  | 6   |         |
| $t_{PAN}$ | Address to Output (turn-on to high level)                              |   |   | 150 | 200 | ns  | 7   |         |
| $t_{PSF}$ | Propagation Delay Time Strobe to Output (switch turn-off)              |   |   | 150 | 200 | ns  | 5   |         |
| $t_{PZL}$ | Data-in to Output (turn-on to low level)                               |   |   | 150 | 200 | ns  | 6   |         |
| $t_{PAF}$ | Address to Output (turn-off)   |   |   | 150 | 200 | ns  | 7   |         |
| $t_S$     | Set-up Time Data-in to Strobe  |   |   | 40  |     |     | ns  | 5<br>10 |
| $t_H$     | Hold Time Data-in to Strobe  |   |   | 120 |     |     | ns  | 5<br>10 |
| $t_O$     | Switching Frequency  |   |   |     | 1   |     | MHz |         |
| $t_W$     | Strobe Pulse Width   |   |   | 100 |     |     | ns  | 10      |
| $t_{WR}$  | Reset Pulse Width  |   |   | 150 |     |     | ns  | 9       |
| $t_{PHZ}$ | Reset Turn-off to Output Delay   |   |   |     | 150 | 200 | ns  | 9       |
| $t_{AS}$  | Address Set-up Time Address to Strobe                                  |   |   | 120 |     |     | ns  | 10      |
| $t_{AH}$  | Address Hold Time Address to Strobe                                    |   |   | 120 |     |     | ns  | 10      |
|           | Control Crosstalk Data-in, Address or Strobe to Output                 |   | Square wave input, $V_{IN} = 3\text{V}$ ,<br>$R_L = 10\text{k}\Omega$ |     | 75  |     | mV  | 8       |

TEST CIRCUITS

Figure 1 : R<sub>ON</sub> Measurement.

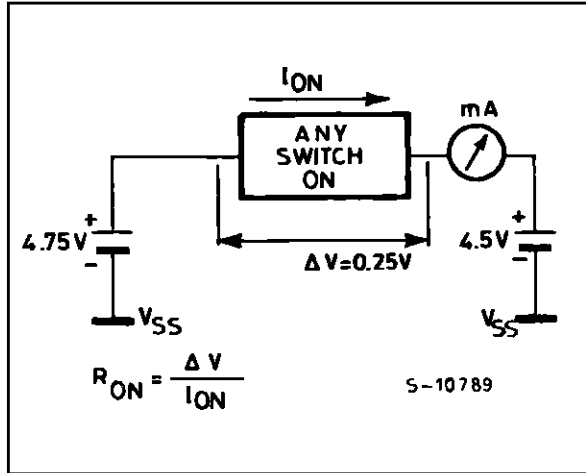


Figure 2 : Propagation Delay Time and Waveforms (signal input to signal output switch ON).

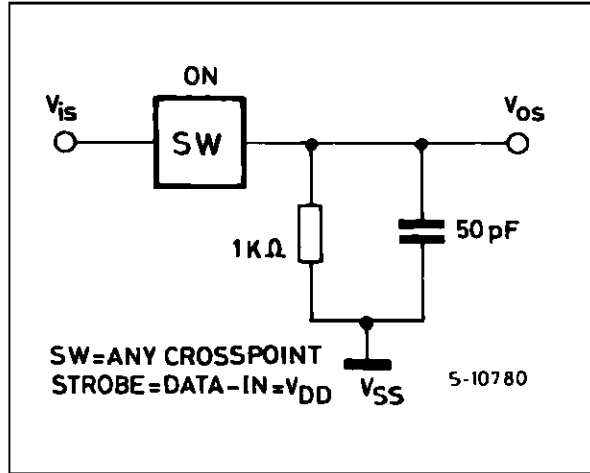


Figure 3 : Off Isolation Measurement (Feed through).

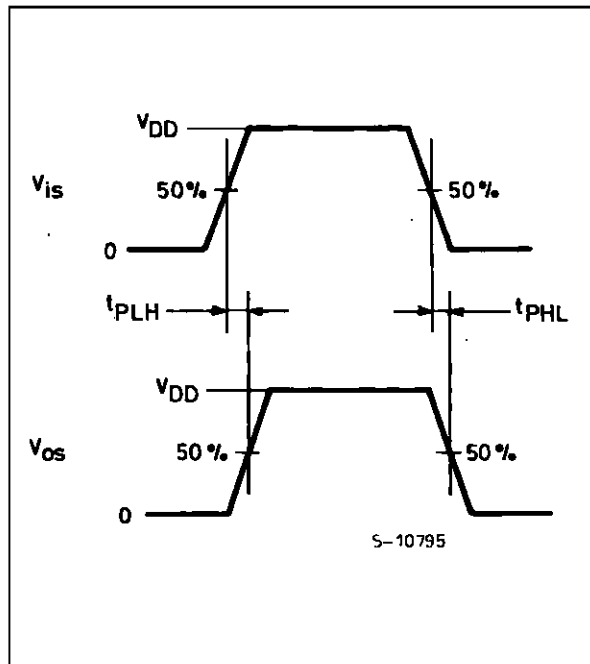
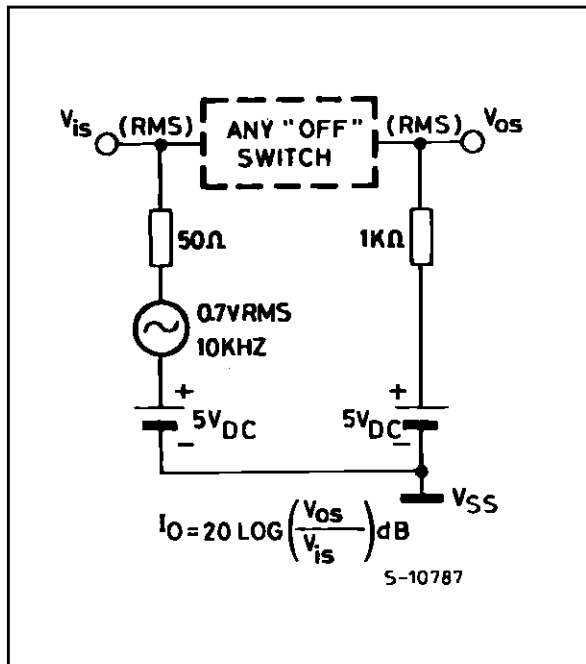


Figure 4 : Crosstalk Measurements.

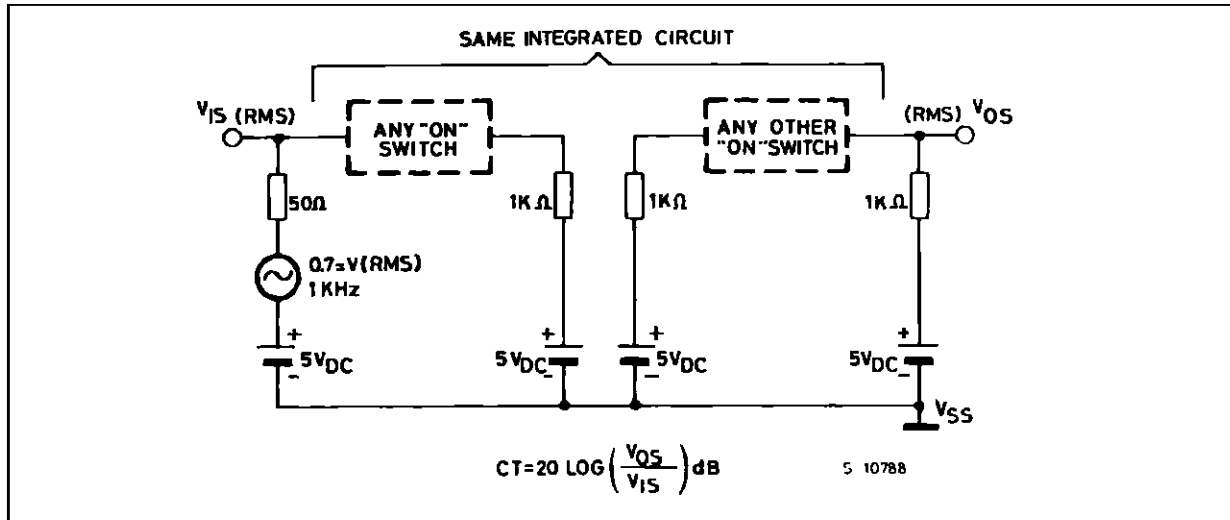


Figure 5 : Propagation Delay Time and Waveforms (strobe to signal output switch Turn-ON or Turn-OFF).

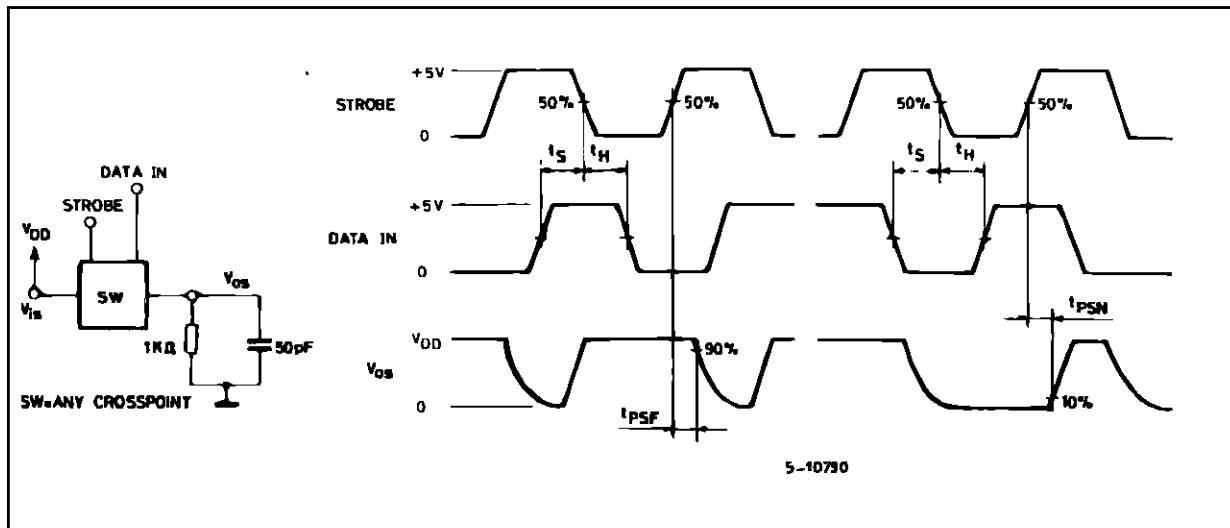


Figure 6 : Propagation Delay Time and Waveforms (data-in signal output, switch Turn-ON to high or low level).

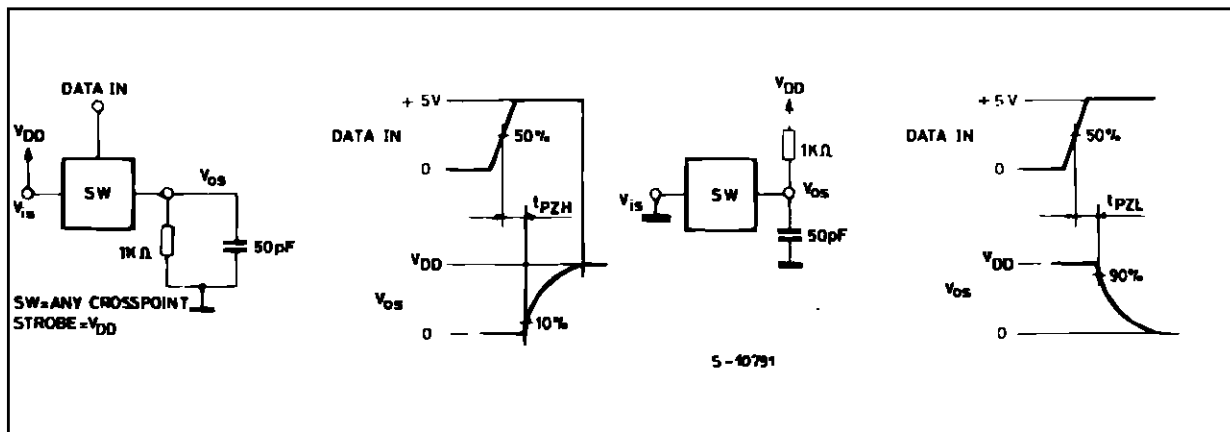


Figure 7 : Propagation Delay Time and Waveforms (address to signal output switch Turn-ON or Turn-OFF).

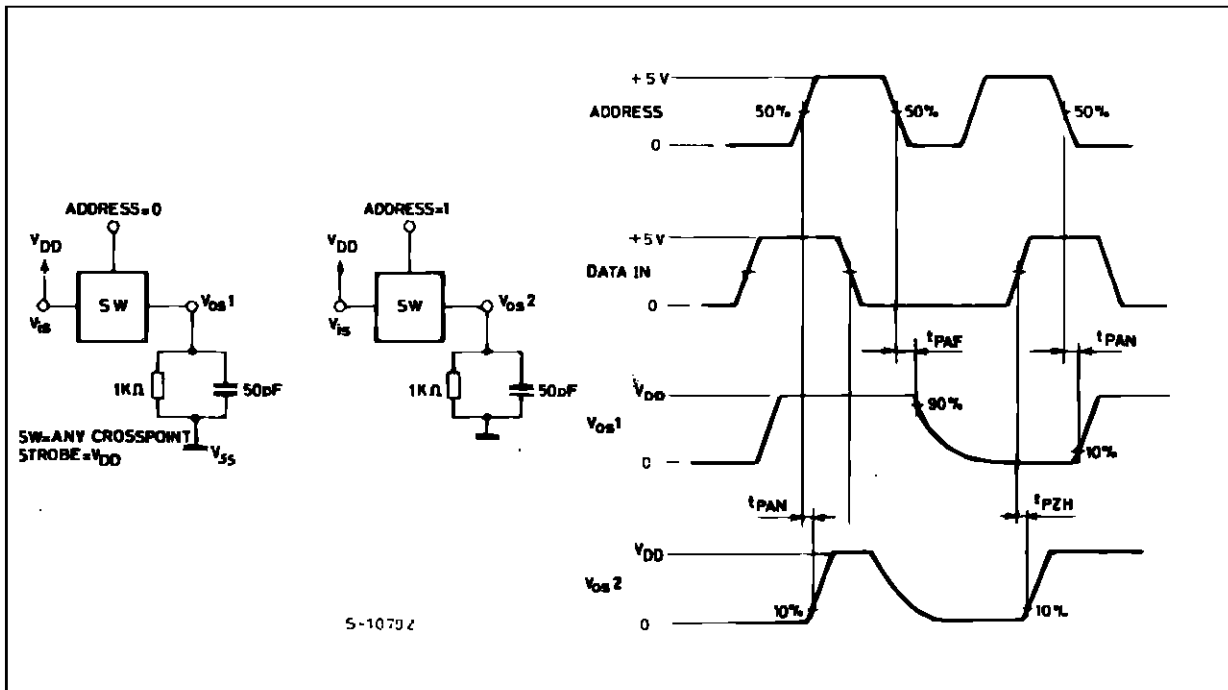


Figure 8 : Waveforms for Crosstalk (control input to signal output).

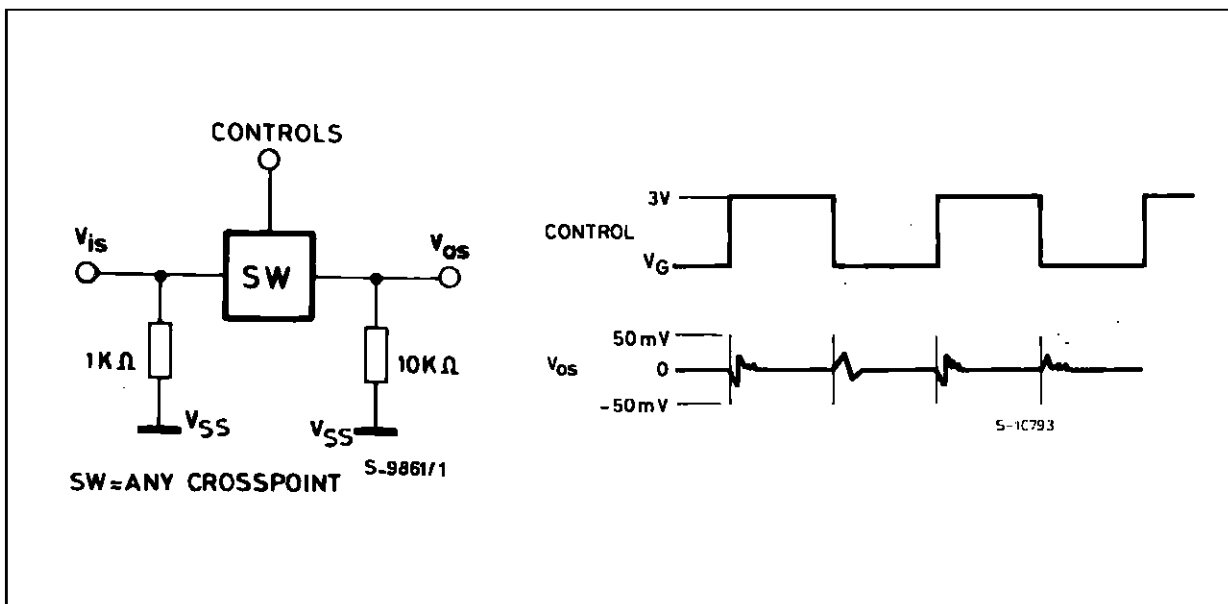


Figure 9 : Propagation Delay Time and Waveforms (reset to output delay).

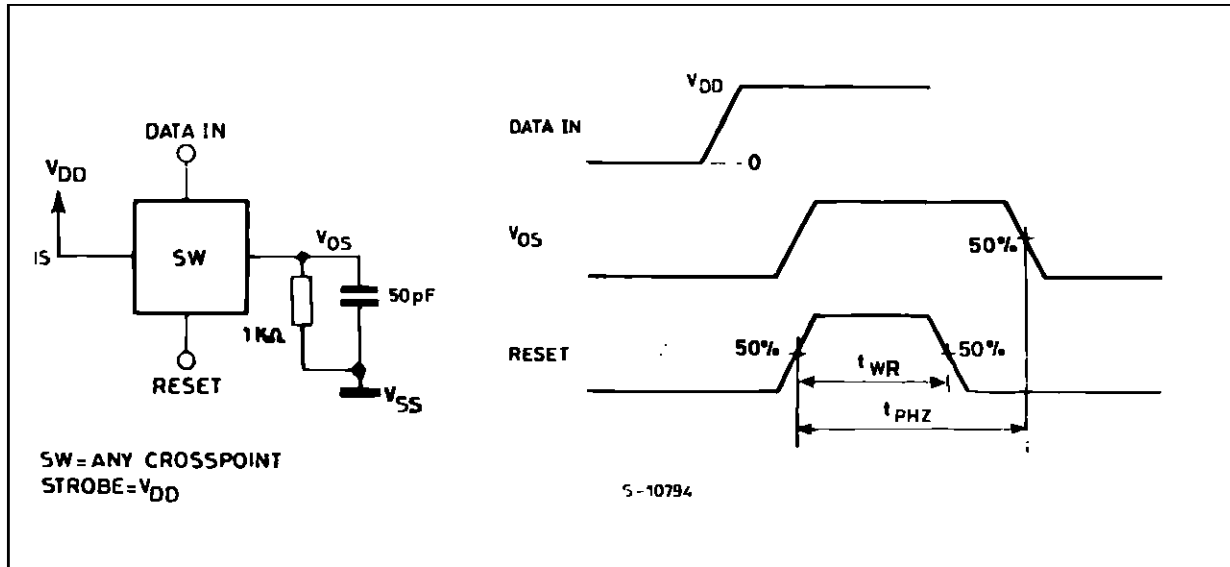


Figure 10 : Propagation Delay Time and Waveforms (Strobe and C/S to signal output switch).

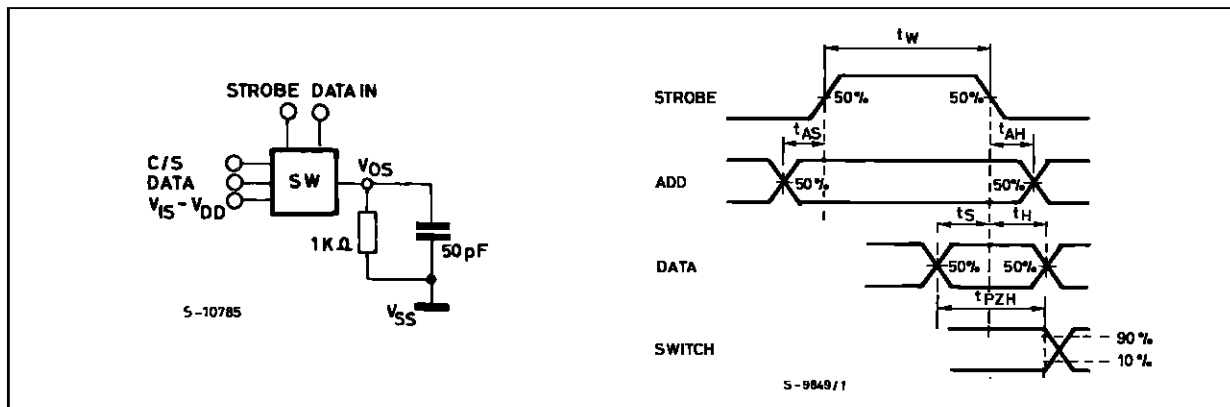




Figure 11 : Typical  $R_{ON}$  versus  $V_{IS}$ .

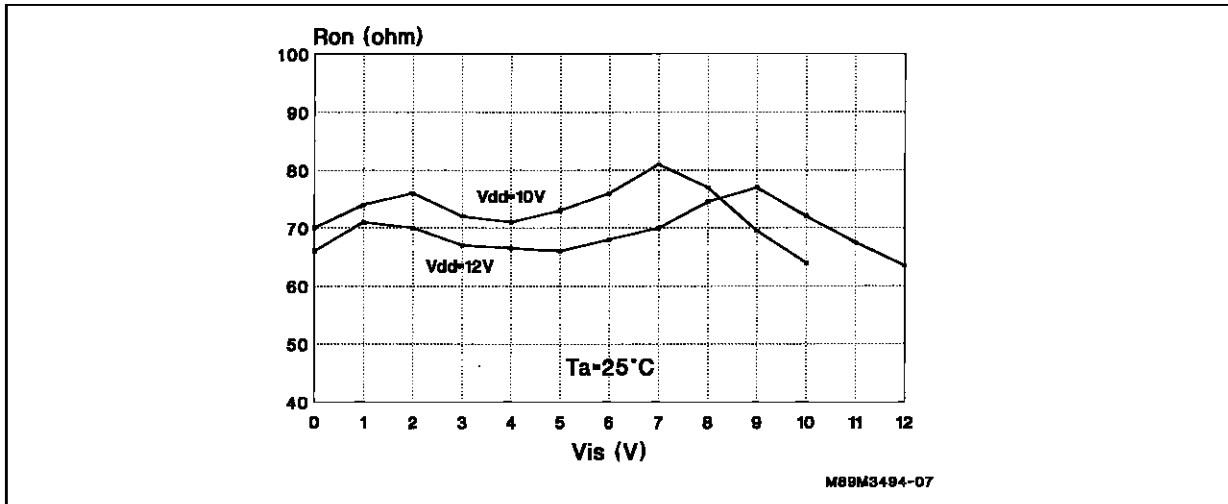


Figure 12 : Peak to Peak Voltage Capability versus Total Harmonic Distortion.

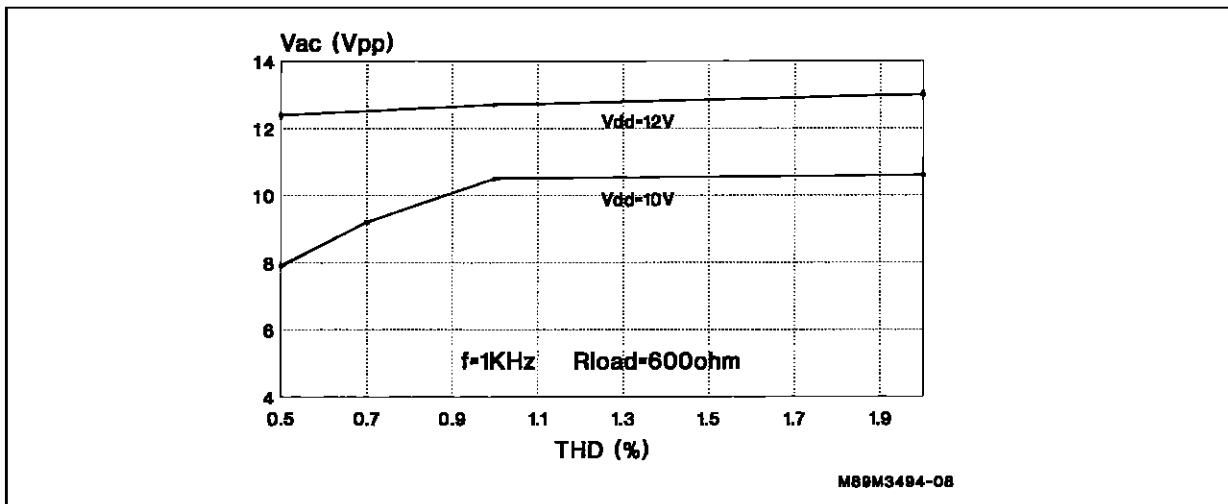
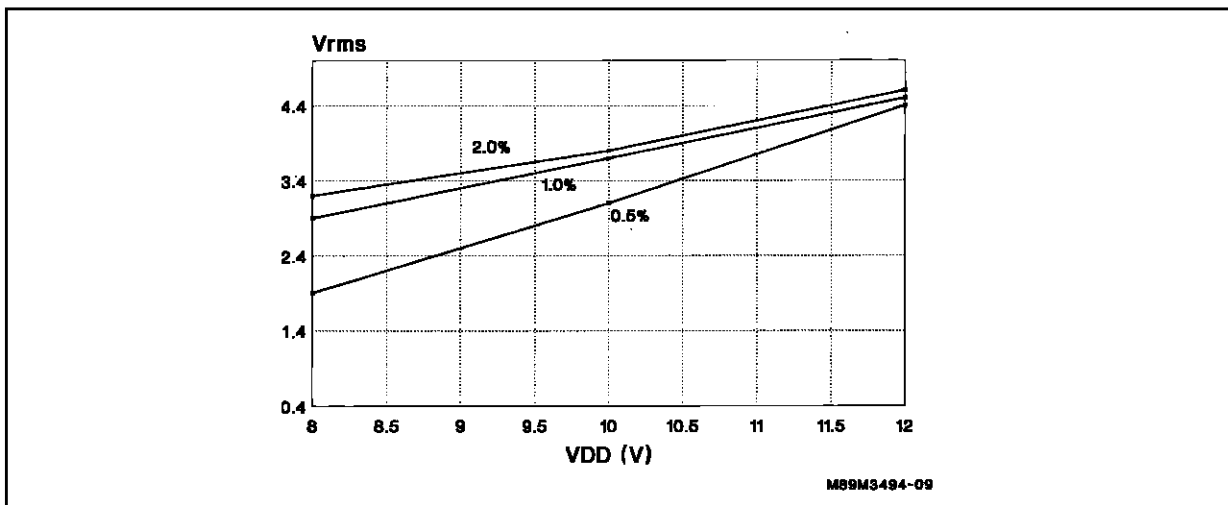


Figure 13 :  $V_{RMS}$  Capability versus  $V_{DD}$ .

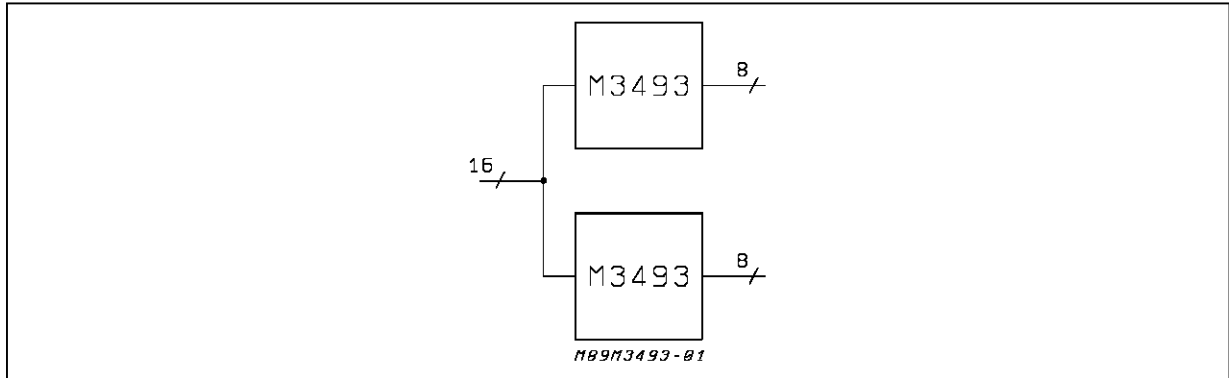


# M3493

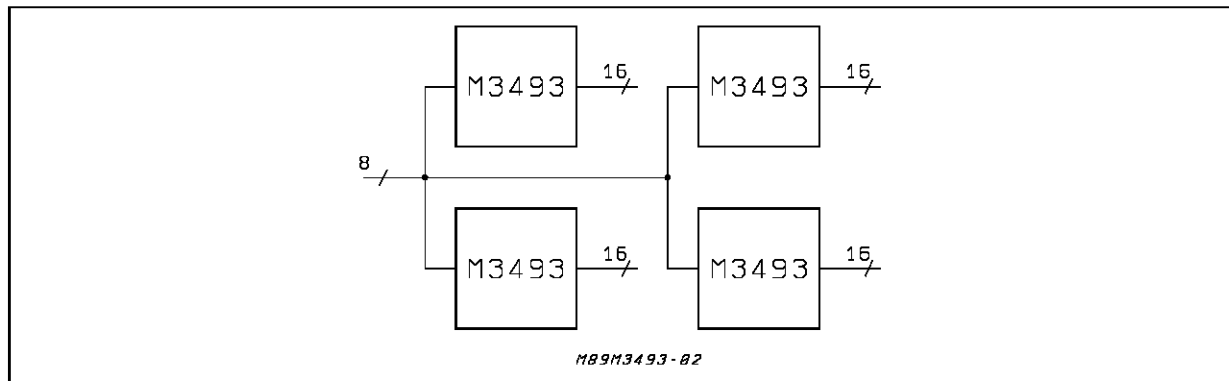
## TYPICAL APPLICATIONS

The figures 14, 15 and 16 show the system configuration for expanded matrices (16 x 16, 8 x 64, 32 x 32).

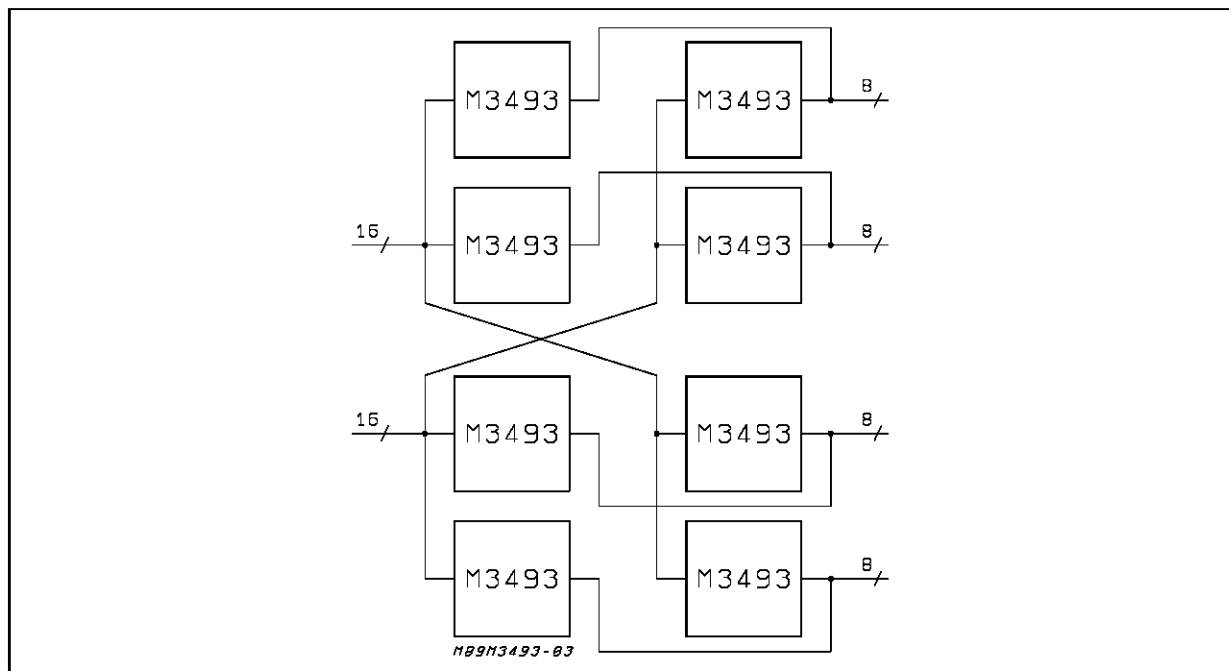
**Figure 14 :** (16 x 16 non blocking matrix).



**Figure 15 :** (8 x 64 matrix).

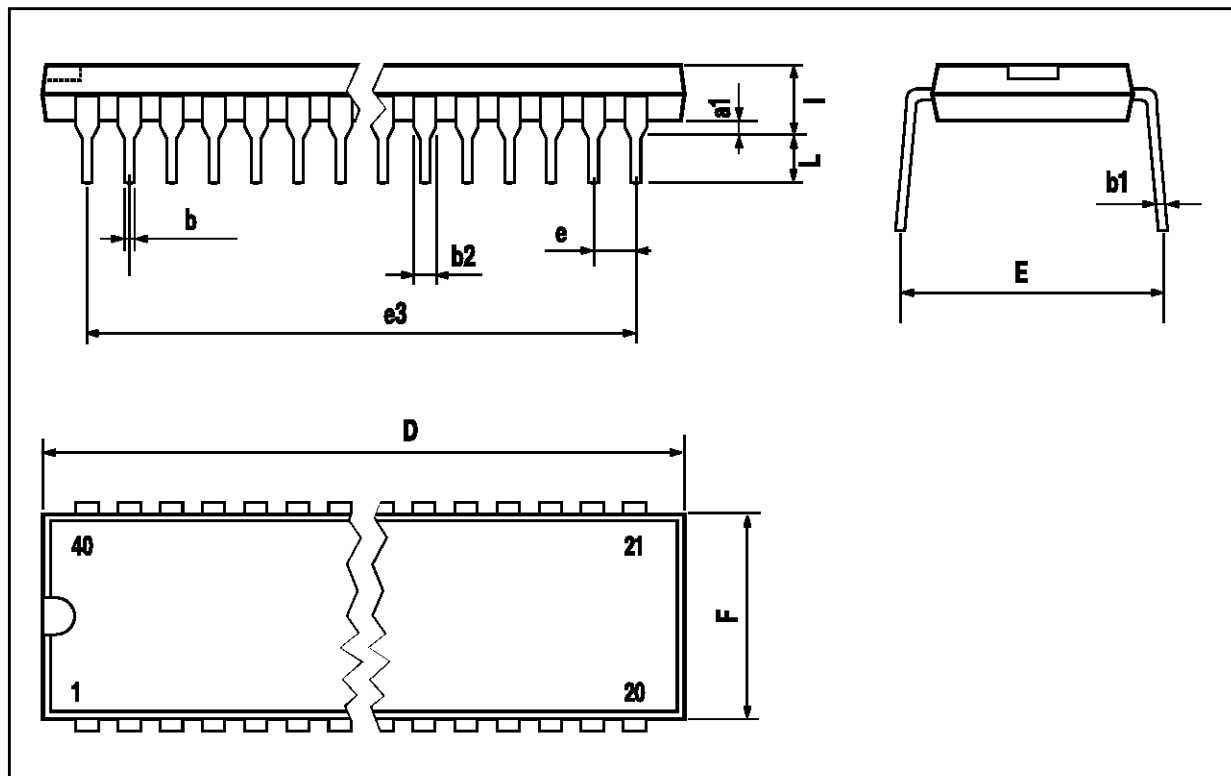


**Figure 16 :** (32 x 32 non blocking matrix).



## DIP40 PACKAGE MECHANICAL DATA

| DIM. | mm   |       |       | inch  |       |       |
|------|------|-------|-------|-------|-------|-------|
|      | MIN  | TYP   | MAX   | MIN   | TYP   | MAX   |
| a1   |      | 0.63  |       |       | 0.025 |       |
| b    |      | 0.45  |       |       | 0.018 |       |
| b1   | 0.23 |       | 0.31  | 0.009 |       | 0.012 |
| b2   |      | 1.27  |       |       | 0.050 |       |
| D    |      |       | 52.58 |       |       | 2.070 |
| E    | 15.2 |       | 16.68 | 0.598 |       | 0.657 |
| e    |      | 2.54  |       |       | 0.100 |       |
| e3   |      | 48.26 |       |       | 1.900 |       |
| F    |      |       | 14.1  |       |       | 0.555 |
| I    |      | 4.445 |       |       | 0.175 |       |
| L    |      | 3.3   |       |       | 0.130 |       |



Information furnished is believed to be accurate and reliable. However, SGS-THOMSON Microelectronics assumes no responsibility for the consequences of use of such information nor for any infringement of patents or other rights of third parties which may result from its use. No licence is granted by implication or otherwise under any patent or patent rights of SGS-THOMSON Microelectronics. Specifications mentioned in this publication are subject to change without notice. This publication supersedes and replaces all information previously supplied. SGS-THOMSON Microelectronics products are not authorized for use as critical components in life support devices or systems without express written approval of SGS-THOMSON Microelectronics.

© 1993 SGS-THOMSON Microelectronics - All Rights Reserved

SGS-THOMSON Microelectronics GROUP OF COMPANIES

Australia - Brazil - China - France - Germany - Hong Kong - Italy - Japan - Korea - Malaysia - Malta - Morocco  
The Netherlands - Singapore - Spain - Sweden - Switzerland - Taiwan - United Kingdom - U.S.A.